

T & A TOOL, INC.

TOOL DESCRIPTION: 3.25 DIA. BACK COUNTERBORE BLADE
 INSERTS: SD-532P, SD-422P
 SCREWS: PT-319T, PT-318T
 MATERIAL: ALLOY H.T.
 TOOL NUMBER: 21-16

TOLERANCES <small>(UNLESS OTHERWISE SPECIFIED)</small>		
x.x	+0.020	-0.020
x.xx	+0.010	-0.010
x.xxx	+0.002	-0.002
x.xxxx	+0.0005	-0.0005
xx°	+30'	-30'
xx°xx'	+15'	-15'

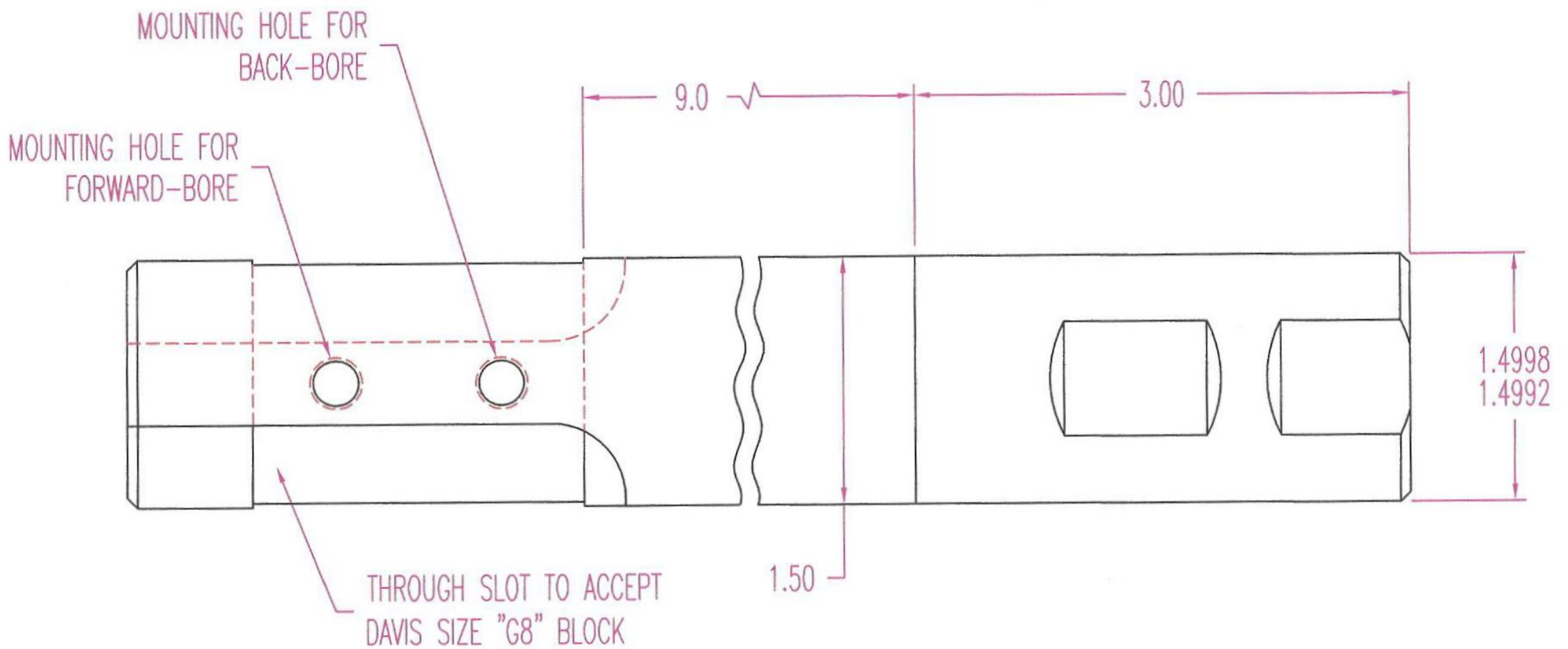

T & A TOOL, INC.

TOOL DESCRIPTION: STRAIGHT-SHANK BAR FOR DAVIS G8 BLADES
 INSERT:
 SCREW:
 MATERIAL: ALLOY H.T.
 TOOL NUMBER: 21-15

TOLERANCES <small>(UNLESS OTHERWISE SPECIFIED)</small>		
x.x	+0.020	-0.020
x.xx	+0.010	-0.010
x.xxx	+0.002	-0.002
x.xxxx	+0.0005	-0.0005
xx°	+30'	-30'
xx°xx'	+15'	-15'