

4 FLUTE / 2 EFFECTIVE

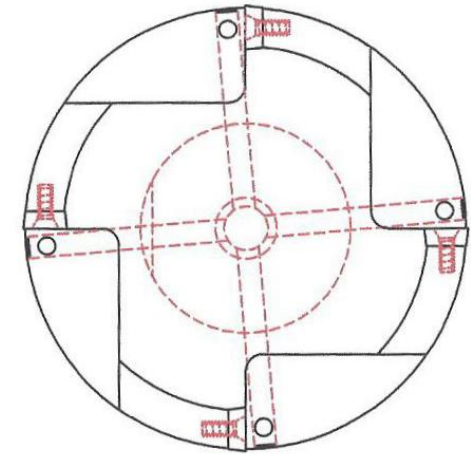

## **T & A TOOL, INC.**

TOOL DESCRIPTION: 3.191 DIA. FINISH TRE-PAN TOOL

INSERT: RCMT 0803M0 (4)

SCREW: C03007, M3 (4)

COOLANT COLLAR: PT-511

MATERIAL: ALLOY H.T.

TOOL NUMER: 287-563-A

TOLERANCES		
x.x	+0.20	-0.20
x.xx	+0.10	-0.10
x.xxx	+0.02	-0.02
x.xxxx	+0.005	-0.005
xx°	+30'	-30'
xx°xx'	+15'	-15'