

TOOL UTILIZES 2-PIECE DESIGN
WITH SPECIAL CLAMP
ALL OTHER DIMENSIONS PER CUSTOMER-
SUPPLIED TOOL PRINT FOR TOOL #1880

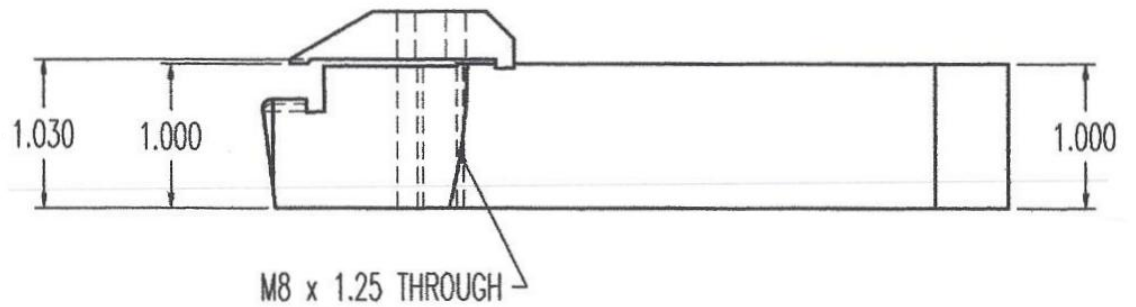
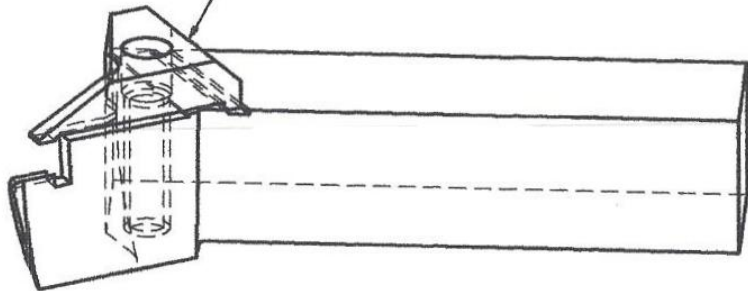

T & A TOOL, INC.

TOOL DESCRIPTION: 30° ANGULAR FACE-GROOVE TOOL

CLAMP: SPECIAL

SCREW: M8 x 1.25 SHCS

MATERIAL: 4340, Rc44-48

TOOL NUMBER: 430-22

TOLERANCES		
x.x	+0.20	-0.20
x.xx	+0.10	-0.10
x.xxx	+0.02	-0.02
x.xxxx	+0.005	-0.005
xx°	+30'	-30'
xx°xx'	+15'	-15'