

ACCEPTS 5/8 S.H.C.S.

4-FLUTE EFFECTIVE

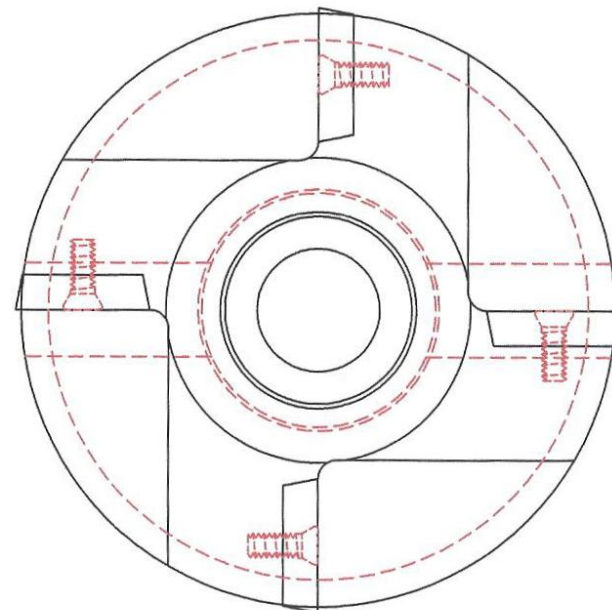

T & A TOOL, INC.

TOOL DESCRIPTION: 3.00 DIA., 15° LEAD FACEMILL

INSERT: GDXMP 2004R (4)

SCREW:

MATERIAL: ALLOY H.T.

TOOL NUMBER: FMUC-15-3

NON-STOCK

TOLERANCES <small>(UNLESS OTHERWISE SPECIFIED)</small>		
x.x	+0.020	-0.020
x.xx	+0.010	-0.010
x.xxx	+0.002	-0.002
x.xxxx	+0.0005	-0.0005
xx°	+30'	-30'
xx°xx'	+15'	-15'