

5-FLUTE EFFECTIVE

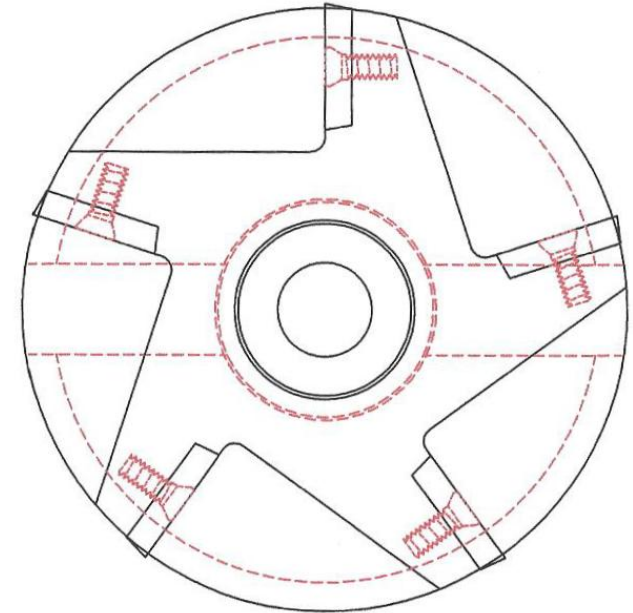

# T & A TOOL, INC.

TOOL DESCRIPTION: 4.00 DIA., 15° LEAD FACEMILL  
 INSERT: GDXMP 2004R (5)  
 SCREW:  
 MATERIAL: ALLOY H.T.  
 TOOL NUMBER: FMUC-15-4

**IN STOCK**

TOLERANCES		
x.x	+0.020	-0.020
x.xx	+0.010	-0.010
x.xxx	+0.002	-0.002
x.xxxx	+0.0005	-0.0005
xx°	+30'	-30'
xx°xx'	+15'	-15'